

TX-NB4-MID

Part number: 650201611G

433,92MHz digital OOK data transmitter 50Ω output connection for external antenna.

Oscillator designed with PLL technique, the device operate in sleep mode and start the wake up procedure with high level transition of input data.

PIN-OUT

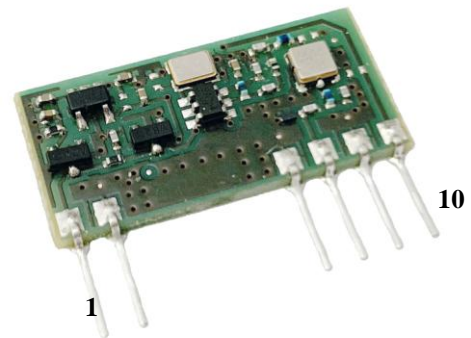
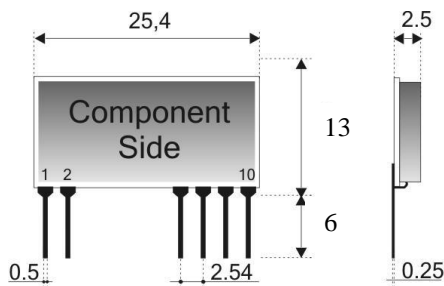

Note: Measure in mm, Pins 1 to 10 spacing 2,54mm

CONNECTIONS

Pin 1	Data input	Data input with minimum 50 kΩ input resistance and 2 - 3,6V range.
Pin 2-7-9	Ground	GND Connections. To be externally connected to single ground plane.
Pin 8	RF Output	RF output with a characteristic impedance of 50Ω
Pin 10	+V	Connection to the positive pole of the DC supply

Technical features TX-NB4-MID

	Min	Tipico	Max	Unità	Annotazioni
Working frequency centre	433.91	433.92	434.93	MHz	See notes 2 and 3
Voltage supply (Vs)	2,3	3,3	12	V	
Absorbed current - Power down		< 1	1	uA	See fig. 2
Absorbed current – PLL active		1,5		mA	See fig. 2
Supply current in TX mode square wave		22		mA	See fig. 2
Supply current in continuous TX mode			40	mA	
RF output power pin 8 antenna	8	12	13	dBm	See note 2
Output impedance pin 8		50		Ω	
RF spurious emissions		-40		dBm	See note 2
Modulation frequency	0,05	5	50	KHz	
Deviation		±20		KHz	
Input high logic level	2	3	3,6	V	See note 1

Technical features are subject to change without notice. AUR°EL S.p.A does not feel responsible for any damage caused by the device's misuse

Input low logic level	0V		0,2	V	
Working temperature	-20		+80	°C	
Dimensions	25,4 x 13 x 2,5 mm				

NOTE 1: It is opportune to limit the max data-input voltage to 3,6V

NOTE 2: Values have been obtained by applying the test system shown in Fig. 1 and maximum 12 V power supply.

NOTE 3: The minimum and maximum showed values are determined by the device's construction tolerance.

The declared technical features have been obtained by applying the following testing system:

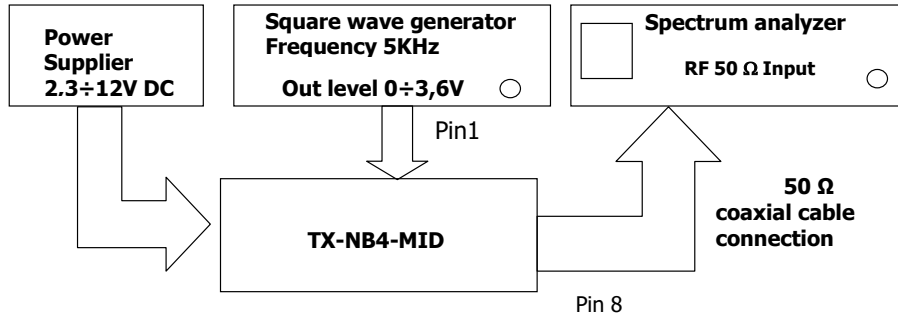
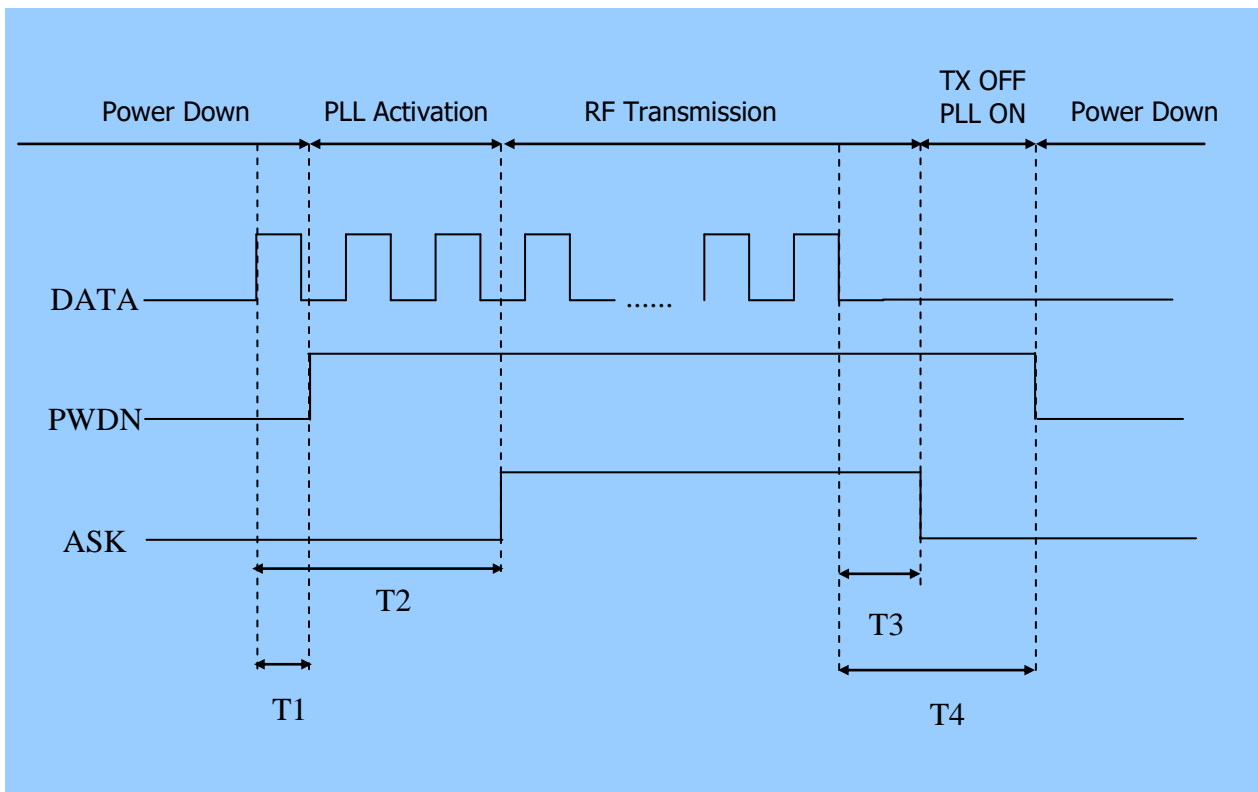

Fig.1

Device Timing

Device present the following switch-on timing:



Technical features are subject to change without notice. AUR°EL S.p.A does not feel responsible for any damage caused by the device's misuse

Fig.2

NOTE: the signal DATA is available to pin 1 of the module, while the signals ASK and PWDN highlighted in the diagram time (Fig 2) are internal to the module, thus are not available in the pins of the module itself.

Here following are reported switch-on and switch-off timing :

Voltage Supply (V)	T1	T2	T3	T4
2,3 – 12	350µs	0,7ms	20ms	20,5ms

Tab. 1

RF transmission start only in case PWDN and ASK are High.

In case PWDN high and ASK low, PLL is active but there is no transmission. With PWDN High, after 0,7ms the RF power is activated to permit PLL to lock in frequency preventing to spread the RF spectrum.

The ASK and PWDN signal is internal to the module, the data input pin trigger a logic sequence machine that controls the PWDN and ASK signals.

Transmission start 0,7ms after first data coming to the pin Data input so first bits are not transmitted.

In the first phase of deactivation the ASK is set down (After T3 from last data), inhibit transmission while keeping the device turned on and PLL locked, finally (After T4) keeps Transmitter in PWDN.

Deactivation phase is kept deliberately 90ms long so that using encodings with long pauses between one frame and the subsequent, it stay ready to transmit the new frame, and not lost the first bit as the first frame.

Device usage

In order to obtain the performances described in the technical specifications and to comply with the operating conditions, which characterize the Certification, the transmitter has to be mounted on a printed circuit, and keep into consideration what follows:

Supply :

1. The transmitter must be supplied by a very low voltage source, safely protected against short circuits. Maximum voltage variations allowed: 2,3÷12,5V.
2. De-coupling, next to the transmitter, by means of a minimum 100.000 pF ceramic capacitor.

Ground:

It must surround at the best the welding area of the transmitter. The circuit must be double layer, with throughout vias to the ground planes, approximately each 15 mm.

It must be properly dimensioned, especially in the antenna connection area, in case a radiating whip antenna is fitted in it (an area of approximately 50 mm radius is suggested).

Technical features are subject to change without notice. AUR°EL S.p.A does not feel responsible for any damage caused by the device's misuse

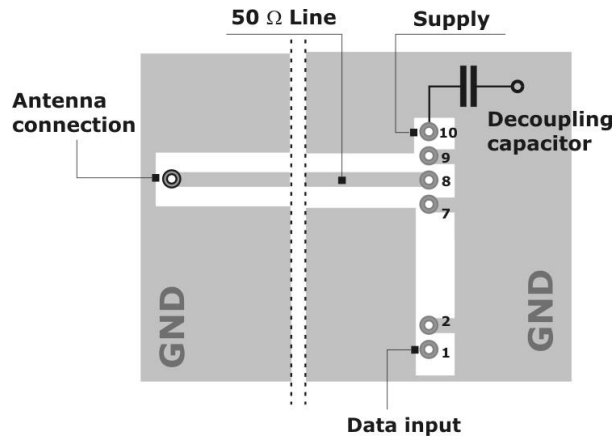

Fig.3 – Suggested Lay-out for best performances

50 Ohm line:

1. It must be the shortest as possible.
2. 1,8 mm wide for 1 mm thick FR4 printed circuits and 2,9 mm wide for 1,6 mm thick FR4 printed circuits. It must be kept 3 mm away from the ground circuit on the same side.
3. On the opposite side a ground circuit area must be present.

Antenna connection:

1. It may be utilized as the direct connection point for the radiating whip antenna.
2. It can bear the connection of the central wire of a 50 Ω coaxial cable. Be sure that the braid is welded to the ground in a close point.

Antenna

1. A **whip** antenna, 16,5 mm long and approximately 1 mm diameter, brass or copper wire made, must be connected to the RF output of the transmitter (pin 8), (see fig. 2).
2. The antenna body must be kept straight as much as possible and it must be free from other circuits or metal parts (5 cm minimum suggested distance.)
3. It can be utilized either vertically or horizontally, provided that a good ground plane surrounds the connection point between antenna and transmitter output.

N.B: As an alternative to the a.m. antenna it is possible to fit the whip model manufactured by **AUR°EL** (see related Data Sheet and Application Notes).
By fitting whips too different from the described ones, the EEC Certification is not assured.

Other components:

1. Keep the transmitter separate from all other components of the circuit (more than 5 mm).
2. Keep particularly far away and shielded all microprocessors and their clock circuits.
3. Do not fit components around the 50 Ohm line. Keep them at least at 5 mm distance.

Technical features are subject to change without notice. AUR°EL S.p.A does not feel responsible for any damage caused by the device's misuse

4. If the Antenna Connection is directly used for a radiating whip connection, keep at least 5 cm radius free area. In case a 50 Ω impedance coaxial cable is connected, then 5 mm radius will suffice.

Reference rules

TX-NB4-MID transmitter complies with the EU rules EN 300-220-2 and EN 301-489-3, with 12V max. Supply. The transmitter must be supplied by a very low voltage source, safely protected against short circuits.

The usage of the module is foreseen inside enclosures that guarantee the EN 61000-4-2 normative not directly applicable to the module itself.

This device is compliant with EN 62479, connected to the electromagnetic field human exposition if used with temporal duty cycle not higher than 10%, like foreseen in CEPT 70-03 recommendation.

CEPT 70-03 Recommendation

TX-NB4-MID recommendation is referred to the 433.05 - 434.79 MHz harmonized bandwidth and therefore, in order to comply with local regulations, the device must be used on the time scale with maximum duty-cycle time of 10% (equivalent to 6 minutes of usage on 60 minutes).

User manual revision summary

Release date	Revision user manual	Changes from the previous revision
14/02/2023	1.0	First release
05/10/2023	1.1	Change name and max supply voltage
16/12/2024	1.2	Change the main picture

Technical features are subject to change without notice. AUR°EL S.p.A does not feel responsible for any damage caused by the device's misuse